

“EDL provides technologies and engineering to configure systems that meet special and often unique customer requirements. We listen, study, design, and deliver value.”

EDL's Tight Wrap Forming Shoe Wrapping System



A ½ roll of low density polyethylene film was used to reduce *all of this* corrugated in a Tight Wrap forming Shoe application!

The system for August is a Tight Wrap Forming Shoe Wrapping System. This system combines EDL's unique Tight Wrap Seal System with an Industrial Duty Forming Shoe for total enclosure without the use of a Shrink Tunnel.

This application creates a close fitting bagged total enclosure and consists of an EDL Tight Wrap Side Feed Automatic, model TWSFA 38-30 Wrapper with a 53" Center Folded Film Feed, Infeed Conveyor, Film Forming Shoe, Lap Sealer, and Exit Conveyor. This system accepts collations or stacks of product and advances them through a Film Forming Shoe, across the seal jaw, and into the sealing position. The film is formed into a close fitting sleeve around the pack as it is pushed through the film. A pair of hot air sealers is directed at the overlap in the film, forming a rugged lap seal between the layers of film down the length of the pack without the challenges associated with drag or hot wire sealers. A vacuum evacuation system removes excess air from the pack if necessary. As the seal jaw closes, gusseting tuckers engage to create a neat end seal and NATURAL HANDLES for the pack. EDL's unique Tight Wrap seal system ensures that the end seal can be made with significant tension on the film, thereby ensuring a tight pack without shrink. The completed pack exits from the system.

Features and Benefits:

- *Completely Encapsulates Product - keeping product tight in 1 direction without the need of a shrink tunnel!*

Features and Benefits: *Continued*

- *Formed gusset creates handle to replace gathered/hog-tied handle on manually bagged product.*
- *Corrugated Shipper Replacement - creates a snug bag around products, eliminating the need for corrugated packaging.*
- *Reduced Floor Space – no shrink tunnel needed for snug total enclosure.*
- *System will be featured at Pack Expo 2009 in Las Vegas!*

Applications to Look For:

- Any product with dimensions greater than 10" X 10" X 10" that is currently being manually bagged.
- Products that are currently being case-packed, and are particularly heat sensitive but can support their own weight when stacked.
- Products that require snug total enclosure but not necessarily shrink – Tight Wrap Forming Shoe pack style can be very tight in the machine direction and as snug as the tolerance between the product and Forming Shoe will allow in the transverse direction.
- Stacks of cut sheets – non-wovens, absorbent pads, filters, acoustical or insulating panels/sheets.
- Large shipping units that are case packed; only because of challenges in creating an acceptable total enclosure shrink bundle, due to dog ears on high-profile packs.

Why EDL?

EDL has over 40 years of experience designing and manufacturing shrink bundling machinery. The expertise gained and the technology developed over the years has helped us become an industry leader in innovative packaging solutions.

Bring us your application and let us apply our Innovative Solutions! Remember: We listen, study, design, and deliver value to our customers!

The video for this system mentioned above and many others can be viewed via the "Login" section of the EDL website at www.edlpackaging.com. *Login:* edlpackaging *Password:* clients. Please contact your EDL Area Sales Manager for further information.

EDL's Standard Equipment

In addition to being known for delivering "special and often unique" packaging solutions, EDL also supplies a line of standard equipment. Our pre-engineered products include inline, side feed, and semi-automatic systems that can be readily applied to meet and exceed the needs of more common applications. Competitive pricing and short delivery lead times are available on all EDL standard equipment.

This month we are also featuring our EDL Stand Alone Shrink Tunnel System.

EDL's Standard Equipment: *Continued*

Model: ST 42-20-78 (*shown with optional exit conveyor*)

- Will shrink packs requiring up to 42" film width, and up to 20" high
- Standard electrical supply of 460 volts, 3-phase, 60 Hz
- QUICK DELIVERY!

COST: \$ 32,340

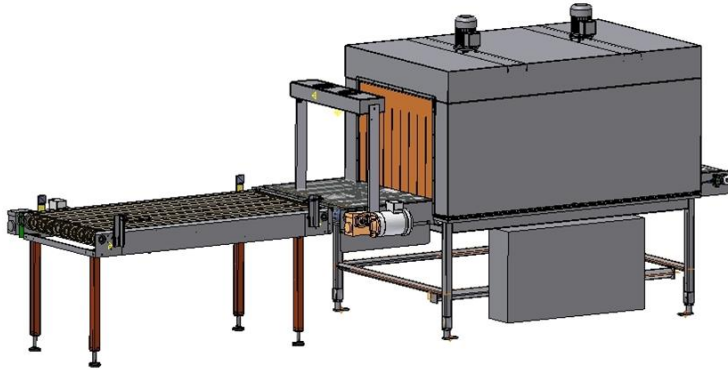

Give our standard equipment line a try. Learn more about our standard equipment at www.edlpackaging.com/edlproducts.html, and then select Bagged, Trayed, or Trayless products. Contact your EDL Area Sales Manager for further information.

EDL SALES TEAM

Ken Carter, President

Area Sales Manager – West
Office: (920) 338-1842 ext. 105
Fax: (920) 336-8585
ken.c@edlpackaging.com

Jarlath Harkin, Sales Director

Area Sales Manager – South
Office: (920) 338-1842 ext. 108
Fax: (920) 336-8585
jarlath.h@edlpackaging.com

Brian Steenrond

Area Sales Manager – Southeast
Office: (920) 569-6333
Fax: (920) 336-8585
brian.s@edlpackaging.com

Bert Jansen

Inside Sales Manager
Office: (920) 338-1842 ext. 124
Fax: (920) 336-8585
bert.j@edlpackaging.com

Deanna Novak

Sales Office Administrator

Office: (920) 338-1842 ext. 110

Fax: (920) 336-8585

deanna.n@edlpackaging.com

EDL Packaging Engineers, Inc.
1260 Parkview Road
Green Bay, WI 54304

Phone: (920) 336-7744

Fax: (920) 336-8585

Website: <http://edlpackaging.com>

Email: sales@edlpackaging.com

Quote of the day:

The sign on the door of opportunity reads PUSH.